

Electro-Pneumatically Controlled On-Off Deluge Valve

Model - FP 400E - 6D



LISTED

Typical Applications



Offshore platforms



Marine environments



Sea water/Corrosive water supplies



Foam fire systems



Increased reliable response by dry solenoid



Dual redundant detection systems

Features and Benefits

- **Dry solenoid** – suitable for corrosive water or foam
- **Remote reset** – shut-off on remote command
- **One-piece molded single moving part** – no maintenance required
- **Simple design** – cost effective
- **Obstacle-free Full-bore** – uncompromising reliability
- **Fully factory pre-assembled trim** – Out-of-Box Quality
- **In-line serviceable** – minimal down time

Optional Features

- **Water Motor Alarm**
- **Alarm Pressure-Switch** (code: P or P7)
- **Explosion proof for hazardous locations** (code: 7 or 8)
- **Fail Safe Open** – energized to close main valve
- **Seawater service** (add FS as prefix to model)

BERMAD Fire Protection

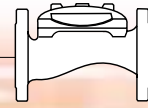

Model - FP 400E - 6D

400 Series

Operation

The BERMAD Model 400E-6D is suited for systems that include electric fire detection and piping system with a wide variety of open nozzles. Being pneumatically controlled, the Model 400E-6D is recommended for those cases, such as seawater installations, where it is advantageous to keep the solenoid [1] dry.

In the SET position, the line-pressure, supplied to the main valve's control chamber [2] through the priming line [3], a Check Valve [4], and an Accelerator [5] with priming restriction, is trapped by the Check Valve, by a Pressure-Operated Relief Valve (PORV) [6] held closed, and by a closed Manual Emergency Release [7]. The trapped pressure holds the main valve's diaphragm and plug against the valve seat [8], sealing it drip-tight and keeps the system piping dry. The PORV is held closed by the dry pilot-line [9] pneumatic pressure through the Solenoid.

In a FIRE or TEST condition, a dry pilot-line pneumatic pressure-drop, or an electric signal that triggers the Solenoid, open the PORV causing water to exit through the Accelerator faster than it can be supplied. Pressure is then released from the main valve's control chamber, through the opened PORV, or the Manual Emergency Release, allowing the main valve to fully-open, and water to flow into the system piping and to the alarm device (if mounted).

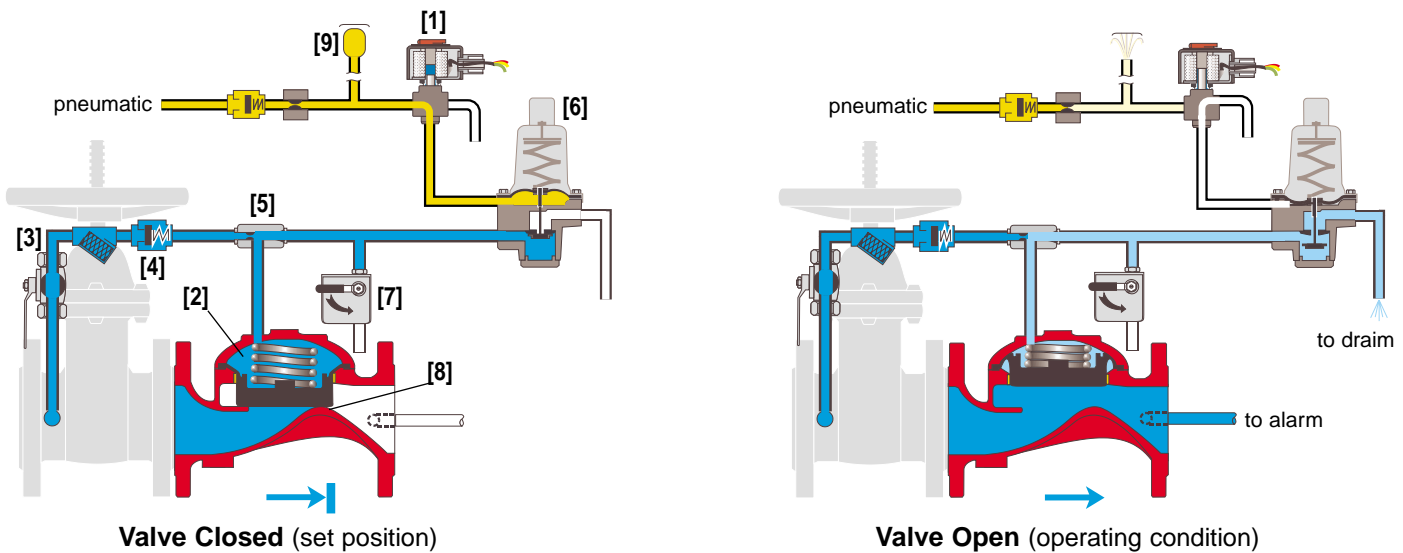

Engineer Specifications

- The deluge valve shall be UL-Listed, pneumatically controlled, elastomeric globe with a **rolling-diaphragm**.
- The valve shall have an **unobstructed flow path**, with no stem guide or **supporting ribs**.
- Valve actuation shall be accomplished by a fully peripherally supported, one-piece balanced rolling-diaphragm, vulcanized with metal insert. The diaphragm assembly shall be the only moving part.
- The valve shall have a removable cover for quick in-line service enabling all necessary inspection and servicing.
- The control trim materials shall be S.S.316 tubing and fittings and plated brass accessories, including, Y strainer, Accelerator, 3-way Solenoid, Pressure-Operated Relief Valve, and Manual Emergency Release.
- The Trim shall be supplied as an assembly, pre-assembled and hydraulically tested at an ISO 9000 and 9001 certified factory.
- The electro-pneumatically remote controlled deluge valve shall open in response to an electric signal or to a dry pilot-line pneumatic pressure-drop.

BERMAD Fire Protection

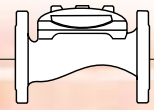

Model - FP 400E - 6D

400 Series



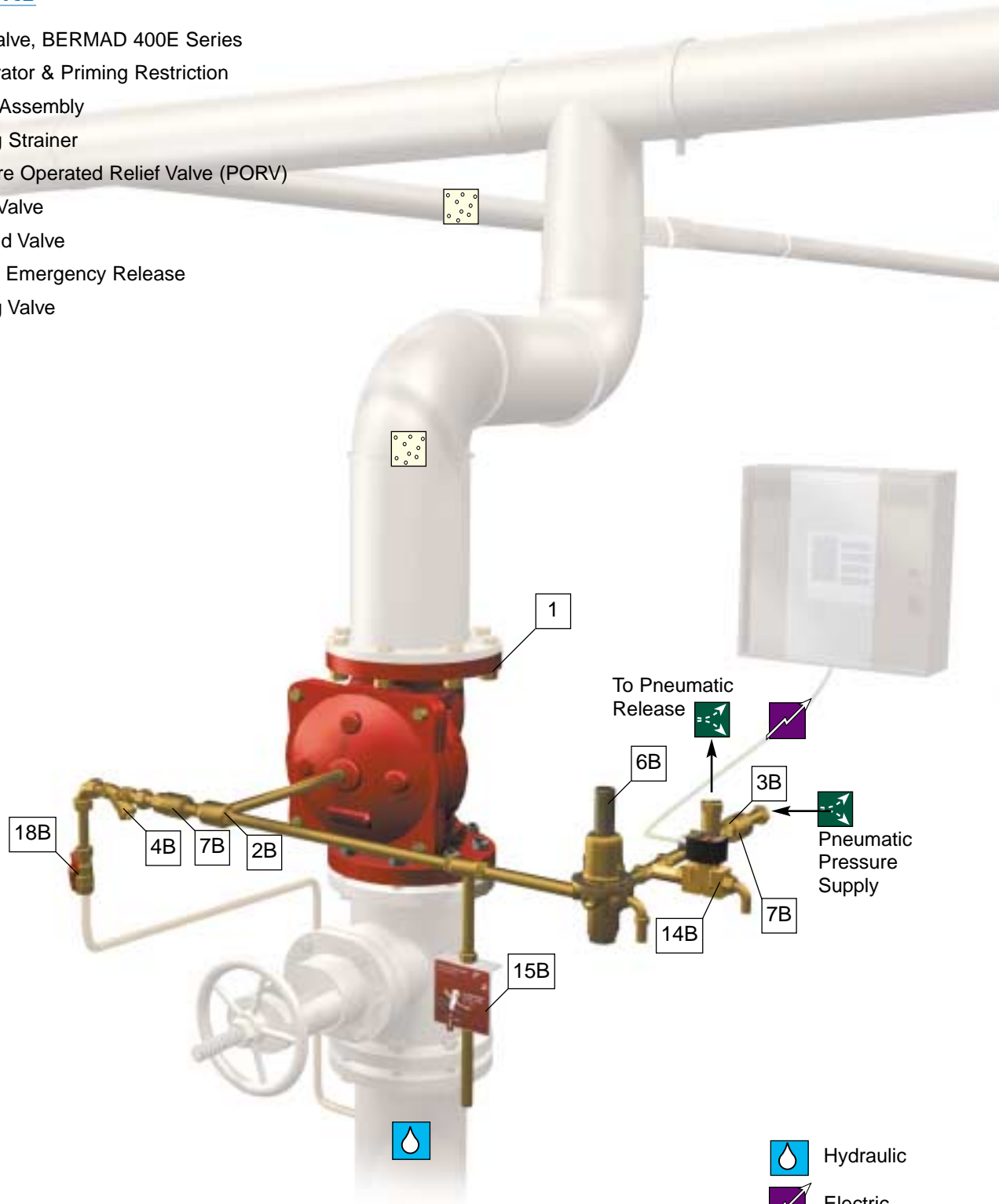

Components

- 1 - Main Valve, BERMAD 400E Series
- 2B - Accelerator & Priming Restriction
- 3B - Orifice Assembly
- 4B - Priming Strainer
- 6B - Pressure Operated Relief Valve (PORV)
- 7B - Check Valve
- 14B - Solenoid Valve
- 15B - Manual Emergency Release
- 18B - Priming Valve



UL-Listed

The BERMAD Model 400E-6D is UL-listed, as a unit, when installed with specific components and accessories.

-  Hydraulic
-  Electric
-  Pneumatic
-  Atmosphere



BERMAD Fire Protection

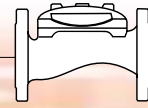

Model - FP 400E - 6D

400 Series

Technical Data

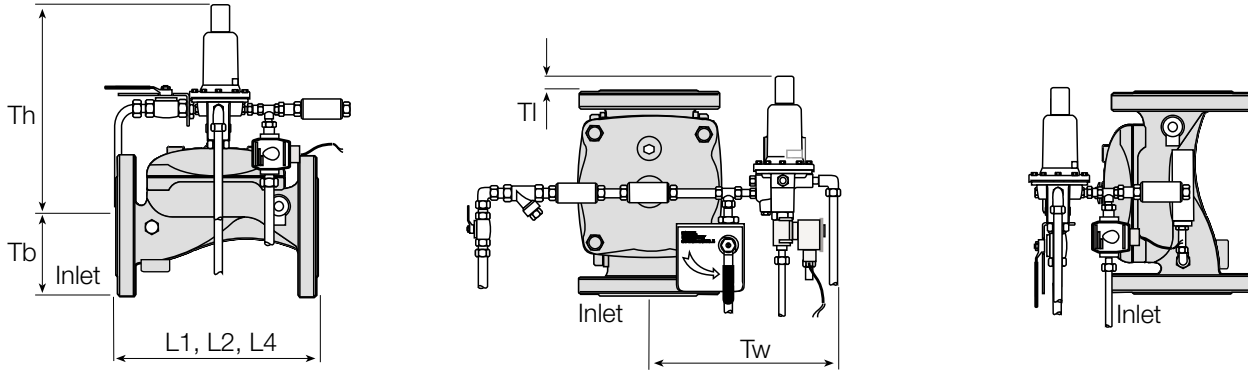

Valve Size	2"		2 1/2"		3"		4"		6"		8"		10"		12"		
	mm	inch	mm	inch	mm	inch	mm	inch	mm	inch	mm	inch	mm	inch	mm	inch	
Dimensions	(1)L1	205	8 1/16	205	8 1/16	250	9 13/16	320	12 5/8	415	16 5/16	500	19 11/16	605	23 13/16	725	28 1/2
	(2)L2	180	7 1/16	210	8 1/4	255	10 1/16	N/A	N/A	N/A	N/A	N/A	N/A	N/A	N/A	N/A	N/A
	(3)L4	205	8 1/16	N/A	N/A	250	9 13/16	320	12 5/8	N/A	N/A	N/A	N/A	N/A	N/A	N/A	N/A
	TI	25	1	25	1	N/A	N/A	N/A	N/A	N/A	N/A	N/A	N/A	N/A	N/A	N/A	N/A
	Tw	318	12 1/2	329	12 15/16	340	13 3/8	352	13 13/16	393	15 1/2	423	16 5/8	443	17 7/16	481	18 15/16
	Th	255	10 1/16	263	10 3/8	272	10 11/16	282	11 1/8	315	12 7/16	332	13	330	13	368	14 1/2
	Tb	78	3 1/16	89	3 1/2	100	4	112	4 7/16	140	5 1/2	170	6 1/16	202	8 15/16	240	9 1/2

Notes:

- L1 is for flanged ANSI #150 and ISO PN16.
- L2 is for threaded female, NPT or BSP.
- L4 is for grooved.
- Provide adequate space around valve for maintenance.
- Data is for envelope dimensions, specific component positioning may vary.

Connection Standard

- Flanged: ANSI B16.42 (Ductile Iron), B16.5 (Steel & Stainless), B16.24 (Bronze) or ISO PN16
- Threaded: NPT or BSP for 2 & 2 1/2
- Grooved: ANSI/AWWA C606 for 2, 3, 4 & 6"

Water Temperature

- 0.5 – 50°C (33 – 122°F)

Available Sizes

- 2, 2 1/2, 3, 4, 6, 8, 10 & 12"
- UL-listed for sizes 2, 2 1/2, 3, 4, 6, & 8"

Pressure Rating

- Max working pressure: 250 psi (17 bar)

Manufacturers Standard Materials

Main valve body and cover

- Ductile iron ASTM A-536

Main valve internals

- Stainless steel 304 & Cast iron

Control Trim System

- Brass control Components/Accessories
- Stainless steel 316 tubing & fittings

Elastomers

- Nylon fabric reinforced polyisoprene

Coating

- Electrostatic Powder Coating Poleyester
- Red (RAL 3000)

"PORV set - opens on pressure drop

- Factory set: 20 psi (1.5 bar)
- Adjustable range: 10-75 psi (0.7-5 bar)

Optional Materials

Main valve body

- Carbon steel ASTM A-216 WCB
- Stainless steel 316
- Ni-Al bronze ASTM B-148

Control Trim

- Stainless steel 316
- Monel®
- Hastalloy C-276

Elastomers

- NBR
- EPDM

Coating

- High Built Epoxy Fusion-Bonded with UV Protection, Anti-Corrosive

Solenoid Pilot Valve

Standard

- 2-way brass body
- Main valve closed when de-energized
- Enclosure: General purpose watertight, NEMA 4 and 4X / IP65
- Optional: Explosion-proof NEMA 6, 6P, 7 & 9

Voltage

- 24, 120, DC
- 24, 110, 220, AC 50 Hz (or 24, 120, 240, AC 60 Hz)
- Continuous duty-molded Class F
- Wattage rating: 10.6 DC, 9.5 AC

Approvals

- UL-Listed, CSA Certified
- Alternative: ATEX / IEC certified
- Other solenoids available on request



info@bermad.com • www.bermad.com

The information contained in this document is subject to change without notice. BERMAD shall not be liable for any errors contained herein. All rights reserved © Copyright by BERMAD. PE4PE-6D 04