

Double-Interlock Preaction, Electric-Pneumatic Release System

Model - FP 400E - 7DM



Description

The BERMAD Model 400-7DM Double-Interlock Preaction, Electric-Pneumatic Release System is suitable for use in systems requiring that water be kept out of the sprinkler piping until an electric detecting device and a sprinkler have both been activated. Electric-pneumatic double-interlock systems include automatic sprinklers attached to a dry sprinkler piping system, with a supplementary electric detection system and a Pneumatic Supervised System of air pressure in the system piping, installed in the same area. The Supervised System consists of a Pneumatic Pilot Valve, pneumatic low-pressure supply and an additional listed check-valve including trim with low-pressure switch, installed downstream from the Preaction Valve. The Electric-Pneumatic double-interlock system admits water into the sprinkler piping only when both the detection and the supervised systems have been simultaneously activated.

Typical Applications



Water-damageable material storage:

- Computer & Electronics Rooms
- Libraries, Museums & Archives
- Telecommunication equipment
- Cable spreading rooms
- Oil-filled-transformer rooms



Freezing conditions

Features and Benefits

- **EasyLock Manual Reset with integral Check Valve – Latch Open**
- **Factory pre-assembled trim – Out-of Box-Quality**
- **Advanced globe wide-body design**
 - Peripherally supported, one-piece balanced rolling-diaphragm with metal insert
 - Reliable drip-tight, leak-proof seal under all conditions
 - Only one moving assembly

Optional Features

- Explosion-proof for hazardous areas
- Air compressor
- Air pressure maintenance device
- Water motor alarm

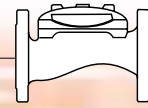

Operation

In the SET position, the line-pressure supplied to the main valve's control chamber [1] via the priming line [2] and through an EasyLock Manual Reset device (EMR) [3], is trapped by the EMR's internal check valve, by a closed Solenoid Valve [4] and by a closed Manual Emergency Release [5]. The trapped pressure holds the main valve's diaphragm and plug against the valve seat [6], sealing it bubble-tight. The piping system is filled with monitory low air pressure to ensure all sprinklers [F] are sealed.

In the event of FIRE, automatic sprinkler activation causes a pneumatic pressure-drop that opens a Pneumatic Pilot Valve (PORV) [7] and activates an alarm, but the main valve remains closed. Only upon opening of both the PORV and the Solenoid Valve (triggered by the electric detection system [E], through a control panel [C]), pressure is released from the main valve's control chamber, through the opened Solenoid Valve and PORV. The EMR prevents line-pressure from entering the control chamber, allowing the main valve to latch open and water to flow into the system piping.

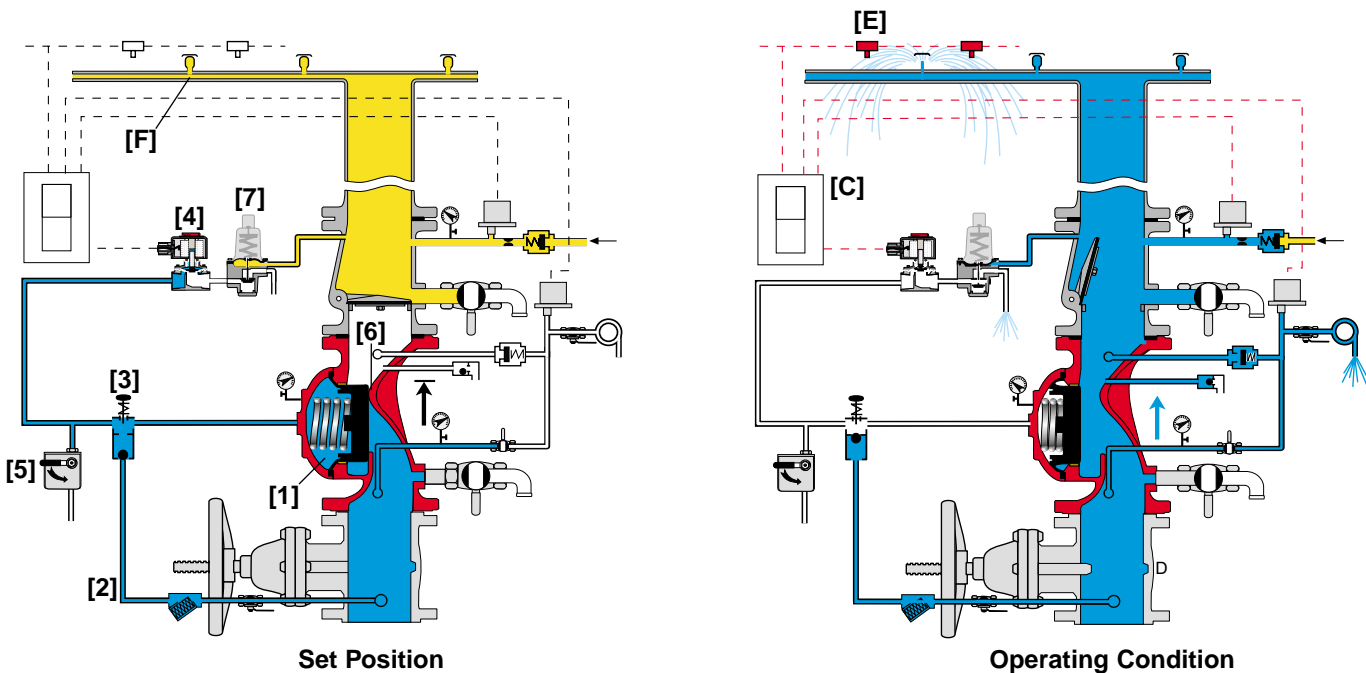

Engineer Specifications

- The pre-action valve shall be UL-Listed, electrically-controlled, elastomeric globe with a **rolling-diaphragm**.
- The valve shall have an **unobstructed flow path**, with no stem guide or **supporting ribs**.
- Valve actuation shall be accomplished by a fully peripherally supported, one-piece balanced rolling-diaphragm, vulcanized with metal insert. The diaphragm assembly shall be the only moving part.
- The valve shall have a removable cover for quick in-line service enabling all necessary inspection and servicing.
- The control trim materials shall consist of St.St. 316 tubing and fittings, and plated brass accessories, including In-line swing check valve (for 15 PSI maintained-pressure supervised-system), local "EasyLock Manual Reset" (EMR), 2-Way Solenoid Pilot Valve, PORV pneumatic pilot valve, Y strainer and Manual Emergency Release.
- The Trim shall be supplied as an assembly, pre-assembled and hydraulically tested at an ISO 9000 & 9001 certified factory.
- The double-interlock preaction, electric-pneumatic release system shall latch open in response to simultaneous activation of both the solenoid and a releasing device. The system shall reset to close only upon local manual activation of the reset device.

BERMAD Fire Protection

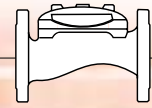

Model - FP 400E - 7DM

400 Series

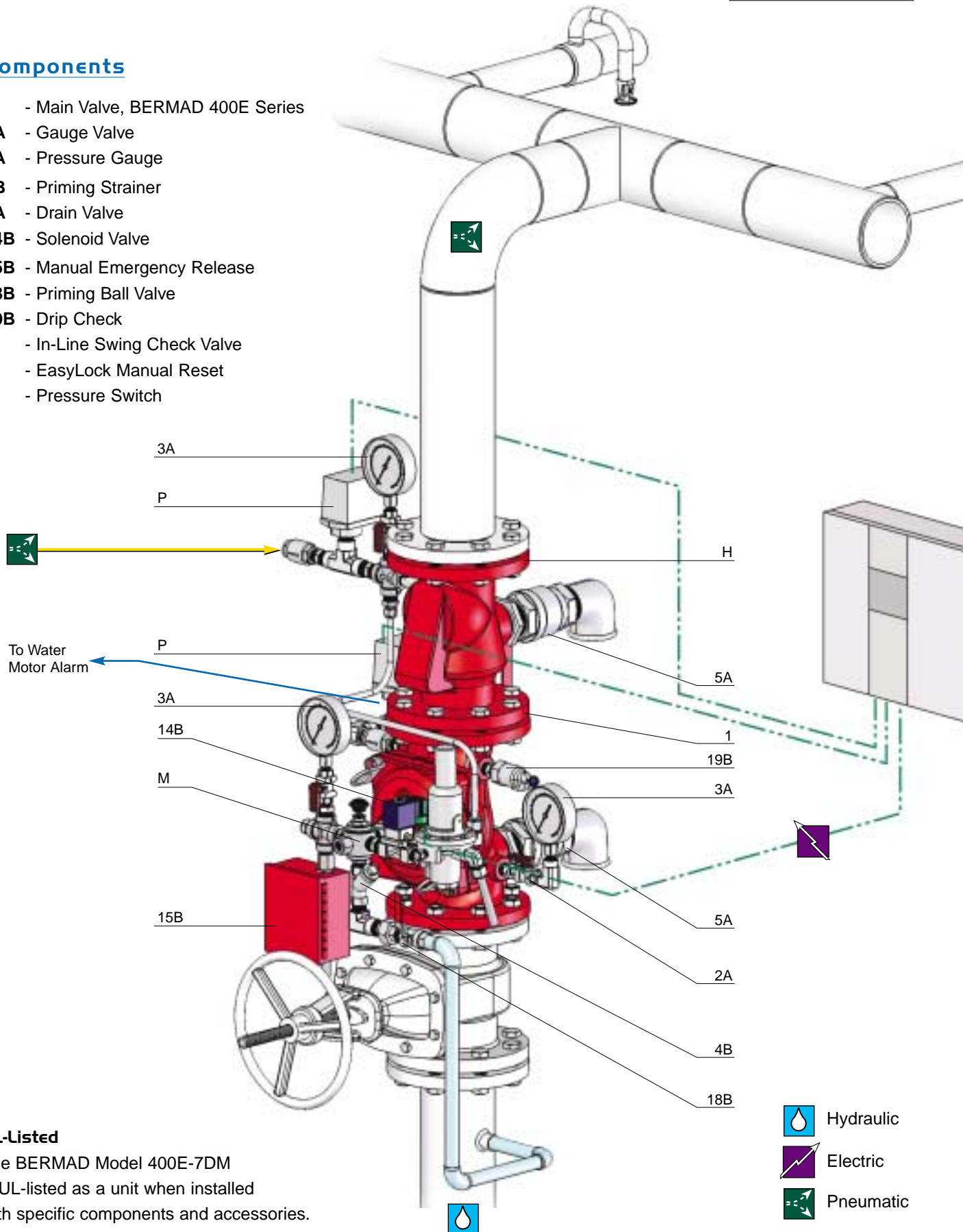

Components

- 1 - Main Valve, BERMAD 400E Series
- 2A - Gauge Valve
- 3A - Pressure Gauge
- 4B - Priming Strainer
- 5A - Drain Valve
- 14B - Solenoid Valve
- 15B - Manual Emergency Release
- 18B - Priming Ball Valve
- 19B - Drip Check
- H - In-Line Swing Check Valve
- M - EasyLock Manual Reset
- P - Pressure Switch



UL-Listed

The BERMAD Model 400E-7DM is UL-listed as a unit when installed with specific components and accessories.

-  Hydraulic
-  Electric
-  Pneumatic



BERMAD Fire Protection

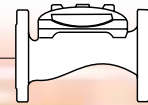

Model - FP 400E - 7DM

400 Series

Technical Data

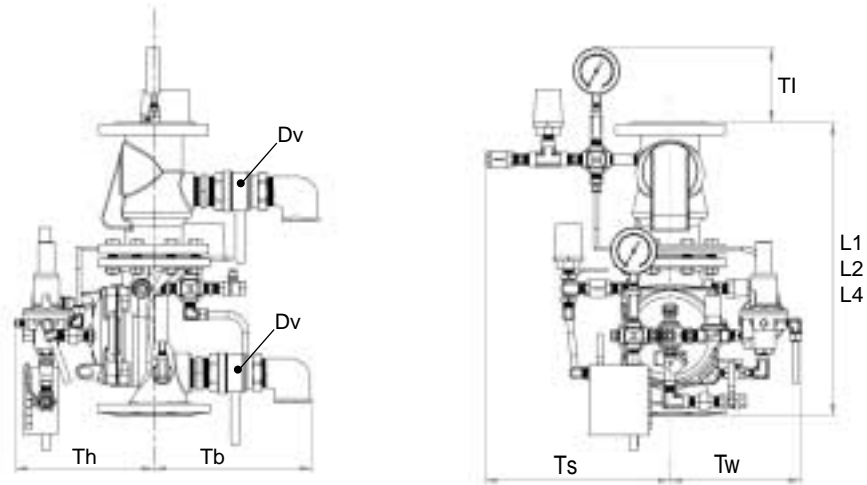

Valve Size	2"		2½"		3"		4"		6"		8"		10"		12"	
	mm	inch	mm	inch	mm	inch	mm	inch	mm	inch	mm	inch	mm	inch	mm	inch
(1)L1	205	8 ¹ / ₁₆	205	8 ¹ / ₁₆	250	9 ¹³ / ₁₆	320	12 ⁵ / ₈	415	16 ⁵ / ₁₆	500	19 ¹¹ / ₁₆	605	23 ¹³ / ₁₆	725	28 ⁹ / ₁₆
(2)L2	180	7 ¹ / ₁₆	210	8 ¹ / ₄	255	10 ¹ / ₁₆	N/A	N/A	N/A	N/A	N/A	N/A	N/A	N/A	N/A	N/A
(3)L4	205	8 ¹ / ₁₆	N/A	N/A	250	9 ¹³ / ₁₆	320	12 ⁵ / ₈	415	16 ⁵ / ₁₆	N/A	N/A	N/A	N/A	N/A	N/A
TI	-	-	150	5 ⁷ / ₈	149	5 ⁷ / ₈	150	5 ⁷ / ₈	135	5 ⁵ / ₁₆	N/A	N/A	N/A	N/A	N/A	N/A
Tw	238	9 ³ / ₈	229	9	253	9 ¹⁵ / ₁₆	263	10 ³ / ₈	302	11 ⁷ / ₈	N/A	N/A	N/A	N/A	N/A	N/A
Ts	-	-	363	14 ¹ / ₄	367	14 ⁷ / ₁₆	371	14 ⁵ / ₈	398	15 ¹¹ / ₁₆	N/A	N/A	N/A	N/A	N/A	N/A
Th	223	8 ¹³ / ₁₆	239	9 ³ / ₈	259	10 ³ / ₁₆	279	11	354	13 ¹⁵ / ₁₆	N/A	N/A	N/A	N/A	N/A	N/A
Tb	230	9 ¹ / ₁₆	290	11 ⁷ / ₁₆	300	11 ¹³ / ₁₆	317	12 ¹ / ₂	338	13 ⁵ / ₁₆	N/A	N/A	N/A	N/A	N/A	N/A
Dv	¾"		1.5"		1.5"		2"		2"		2"		2"		2"	

Notes:

- L1 is for flanged ANSI #150 and ISO PN16.
- L2 is for threaded female, NPT or BSP.
- L4 is for grooved.
- Provide adequate space around valve for maintenance.
- Data is for envelope dimensions, specific component positioning may vary.

Connection Standard

- Flanged:
 - ANSI # 150 to B16.42 (Ductile iron), B16.5 (Steel & Stainless), B16.24 (Bronze)
 - ISO PN16
- Threaded: NPT or BSP 2 & 2 1/2"

Leakage Class

- Class VI (ANSI B16.104)

Manufacturers Standard Materials

Main valve body and cover

- Ductile iron ASTM A-536

Main valve internals

- Stainless steel 304 & Cast iron

Control Trim System

- Brass control Components/Accessories
- Stainless Steel 316 tubing & fittings

Elastomers

- Nylon fabric reinforced polyisoprene

Coating

- Electrostatic Powder Coating
- Poleyster Red (RAL 3000)

Sizes

- UL-listed: 2, 2 1/2, 3, 4, 6 & 8"

Water Temperature

- 0.5 – 80°C (33 – 180°F)

Pressure Rating

- Max working pressure: 250 psi (17 bar)

Optional Materials

Main valve body

- Carbon steel ASTM A-216 WCB
- Stainless steel 316
- Ni-Al bronze ASTM B-148

Control Trim

- Stainless steel 316

Elastomers

- NBR
- EPDM

Coating

- High Built Epoxy Fusion-Bonded with UV Protection, Anti-Corrosive

Solenoid Pilot Valve

Standard model

- Enclosure: General purpose water-tight NEMA 4 and 4X
- Optional: Explosion-proof NEMA 7

Voltage

- 24, 110, 220, AC 50 Hz (or 24, 120, 240, AC 60 Hz)
- 24, 120, DC
- Continuous duty-molded Class F
- Wattage rating: 10.6 DC, 9.5 AC

Approvals

- UL-listed
- CSA Certified
- Alternative: ATEX certified for EEx



info@bermad.com • www.bermad.com

The information contained in this document is subject to change without notice. BERMAD shall not be liable for any errors contained herein. All rights reserved © Copyright by BERMAD. PE4PE-7DM 04