

## Electronic-Control Valve

- Pressure control
- Flow control
- Leakage control
- Level control
- Temperature control
- Mixture control at mixing junction

The Model 718-03 Electronic-Control Valve combines the advantages of an excellent modulating, line-pressure driven, hydraulic control valve with the advantages of electronic control. This valve responds to signals from the electronic controller BERMAD BE (optional) according to the set values programmed into the controller.

For very low pressure applications, refer to the full-powered opening & closing – 718-03-B



### Features and Benefits

- **Line-pressure driven** – independent operation
- **Solenoid-controlled**
  - Low power consumption
  - Wide ranges of pressures and voltages
  - Normally Open, Normally Closed or Last Position
- **Electronic Controller compatible**
  - Local & remote modification of set values
  - Suitable for conventional PLC methods
  - Data logging
- **In-line serviceable** – easy maintenance
- **Double chamber**
  - Full-powered opening (option “B”) & closing
  - Non-slam closing characteristic
  - Protected diaphragm
- **Semi-straight flow** – smooth flow characteristics
- **St. Steel raised seat** – cavitation damage resistant
- **V-Port Throttling Plug** – low-flow stability
- **Flexible design** – easy addition of features

### Major Additional Features

- Full-powered opening & closing – **718-03-B**
- Downstream over-pressure guard – **718-03-48**
- Relief override – **718-03-3Q**
- Check feature – **718-03-20**
- Flow over-the-seat (fail-safe close) – **718-03-O**

See relevant BERMAD publications

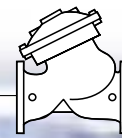

### Operation

The Model 718-03 is an electronic-control valve equipped with two 2-way solenoid pilots. The interaction between the two solenoids determines the required opening position as signaled by the dedicated electronic controller (optional BERMAD BE) [1]. The upstream solenoid [2] applies pressure to the upper control-chamber [3] harnessing valve differential pressure to power the diaphragm-actuator to a more closed position. The downstream solenoid [4] vents upper control-chamber pressure resulting in a more open main valve. Needle valves [5] & [6] control the closing and opening speed of the valve. Valve position can be provided by either an optional limit switch [7], or an analog transducer. In cases where pipeline water is contaminated (corrosive, debris laden) external control fluid is often used.

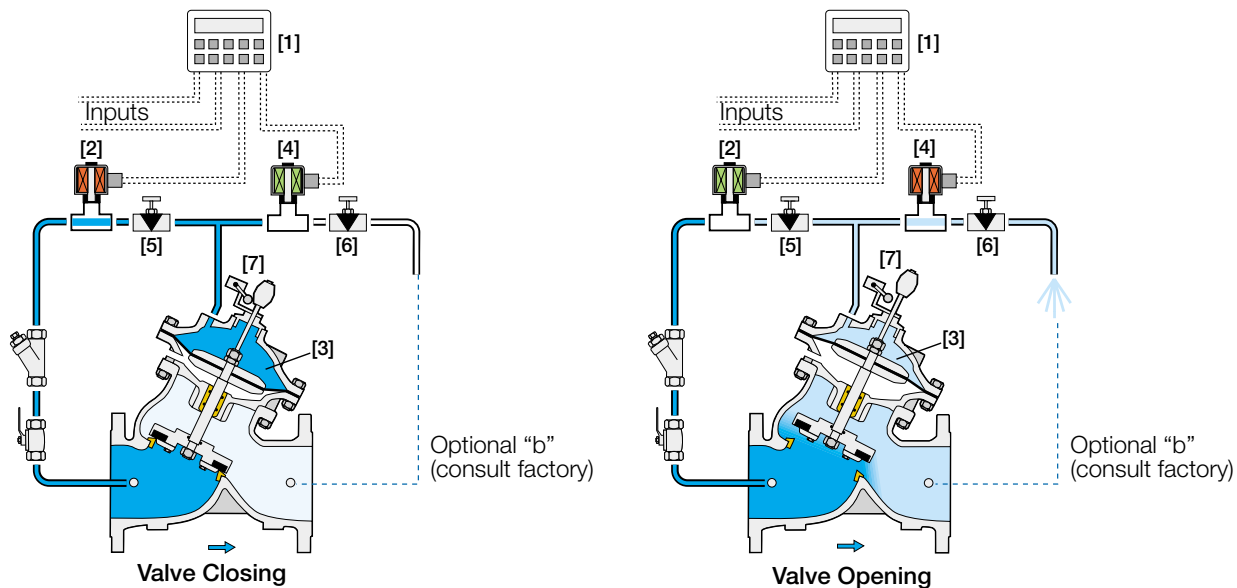

### Tender Specifications

The Electronic-Control Valve shall respond to electric commands by changing its opening position to control a measurable characteristic (pressure, flow, level, salinity, temperature and others).

**Main Valve:** The main valve shall be a center-guided, diaphragm-actuated globe valve of either oblique (Y) or angle pattern design. The body shall have a replaceable, raised, non-threaded, stainless steel seat ring. The valve shall have an unobstructed flow-path, with no stem guides, bearings or supporting ribs. The body and cover shall be ductile iron. All external bolts, nuts, and studs shall be Duplex® coated. All valve components shall be accessible and serviceable without removing the valve from the pipeline.

**Actuator:** The actuator assembly shall be double-chambered with an inherent separating partition between the lower surface of the diaphragm and the main valve. The actuator assembly shall not consist of any closing spring nor spring-like. The entire actuator assembly (seal disk to top cover) shall be removable from the valve as an integral unit. The stainless steel valve-shaft shall be centrally guided by a bearing in the separating partition. The replaceable radial seal disk shall include a resilient seal and shall be capable of accepting a V-Port Throttling Plug by bolting.

**Control System:** The control system shall consist of two 2-way solenoid pilot valves, isolating cock valves, two needle valves and a filter. All fittings shall be forged brass or stainless steel.

The assembled valve shall be hydraulically tested to customer requirements.

**Quality Assurance:** The valve manufacturer shall be certified according to the ISO 9001 Quality Assurance Standard. The valve shall be certified as a complete drinking water valve according to the standards of NSF, WRAS and others.

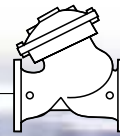

### Electronic Control of a Variable as a Function of Another Variable

This control method is suitable for those applications where dynamic control of a dependant variable, as a programmable function of a governing variable, is required. The system includes a Model 718-03 Electronic-Control Valve, a dedicated electronic controller (optional BERMAD BE), and two transducers (one for each variable).

The controller receives continuous inputs from both transducers and corrects the valve opening in response to a comparison with the set value according to a programmed function.

This system can be used for a wide range of applications, including:

- **Leakage control** – pressure control as a function of flow (see below)
- **Reservoirs applications** – inlet or outlet flow control as a function of reservoir level
- **Heating and cooling systems** – flow control as a function of temperature or  $\Delta P$

### Leakage Control

Optimum network design requires active adjustment of the system set pressure to the minimum possible level.

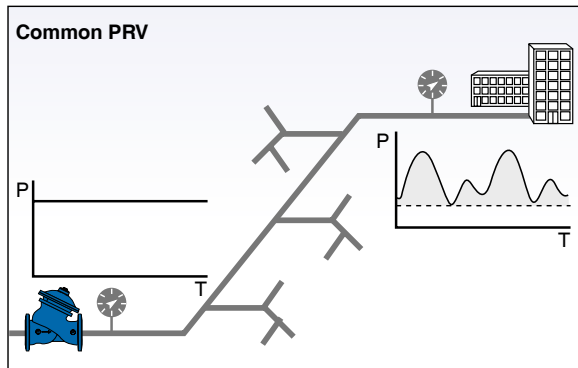

Common PRVs are set to keep the downstream pressure constant ensuring sufficient pressure at the system critical point during "peak" demand (when line friction head-loss is highest).

The shaded area represents the hours and levels when pressure is higher than required.

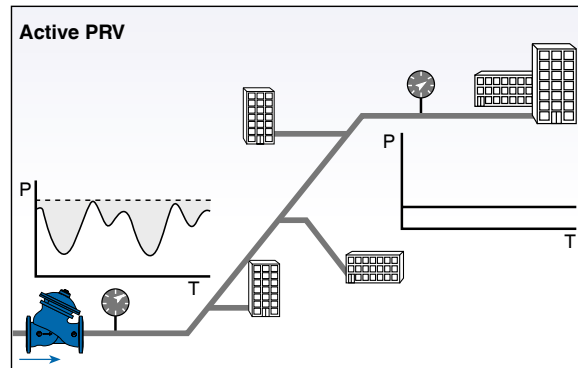

The Model 718-03 and controller continuously corrects the PRV's set value to ensure the minimum required pressure at the system critical point. As a result, the average network pressure dramatically decreases, reducing system leakage flow, burst, maintenance, energy and chemical costs.

The shaded area represents the hours and levels when leakage is reduced.

### Leakage Control-Installation

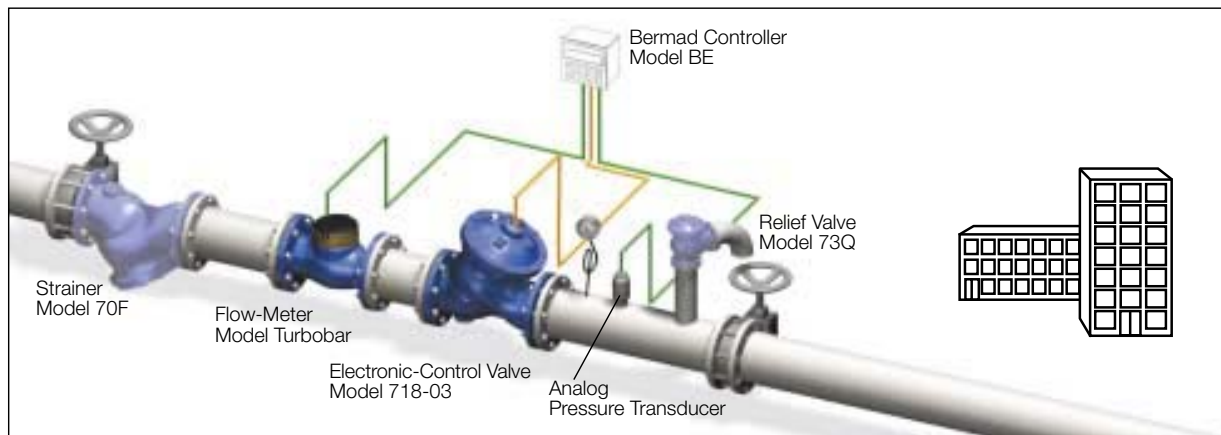

Data logging and analysis of the distribution network parameter values enable establishing a function for real-time adjustment of pressure according to system demand. The flow and pressure transducers continuously transmit to the controller which reacts by adjusting the Model 718-03 according to the pre-established function.



## Electronic Control of a Single Variable

This method is suited for those applications where dynamic control of a variable is required. The system includes a Model 718-03 Electronic-Control Valve, a dedicated electronic controller (optional BERMAD BE), and an analog transducer. The controller receives continuous inputs from the analog transducer and corrects the valve opening in response to a comparison with the programmable set value. The set value can be changed either manually on the controller keyboard or remotely through PC, SMS or and other communication methods.

This system can be used for a wide range of applications including:

- **Pressure control** (see below)
- **Flow control**
- **Level control**

### Pressure Reducing

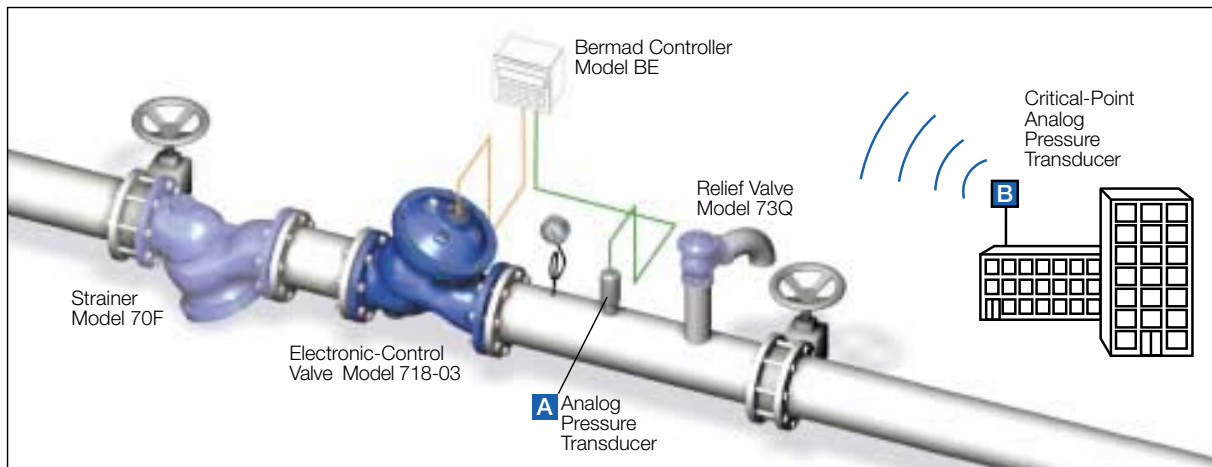

Installing the pressure transducer downstream from the valve provides a pressure-reducing feature.

Either of two methods can be applied:

- Local pressure control as transmitted by pressure transducer **A**.
- Remote pressure control as transmitted by critical point pressure transducer **B**.

### Pressure-Sustaining

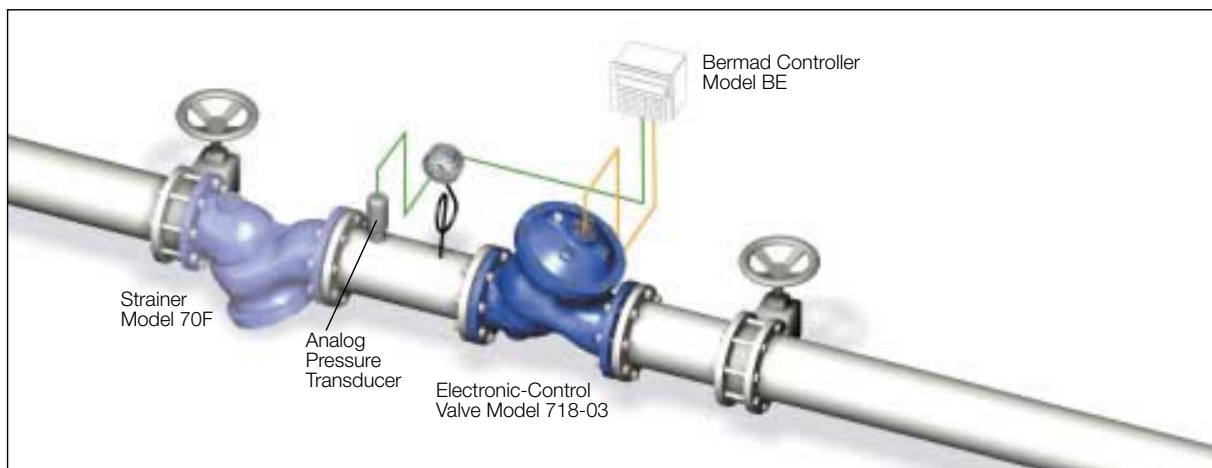

Installing the pressure transducer upstream from the valve provides a pressure-sustaining feature:

- Sustaining pump discharge pressure
- Sustaining circulated discharge pressure
- Sustaining pump suction pressure
- Sustaining reservoir or canal level

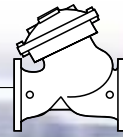

## Electronic Control of Mixing Junctions

This method is suited for dynamic control of two parallel valves controlling the two separate sources of a mixing junction. These systems include two Model 718-03 Electronic-Control Valves, a dedicated electronic controller (optional BERMAD BE). Two types of systems are used.

### **Type A - Sampling the Mixture**

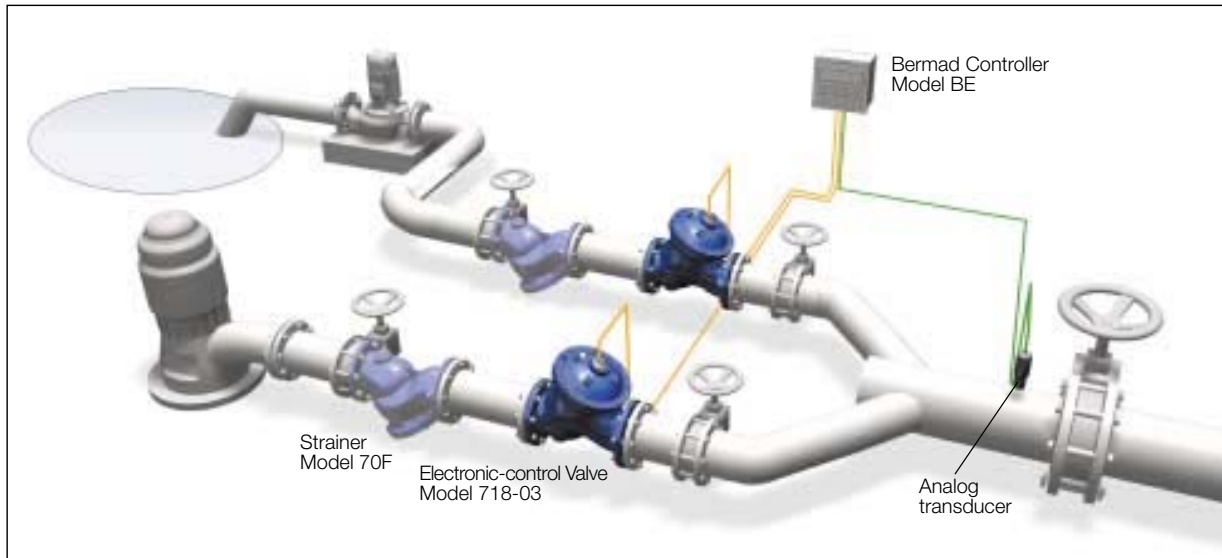

The controller receives continuous inputs from the analog transducer (conductivity, salinity, temperature etc.) and corrects, in real-time, the opening of each valve in comparison with the programmed value.

### **Type B - Sampling the Sources**

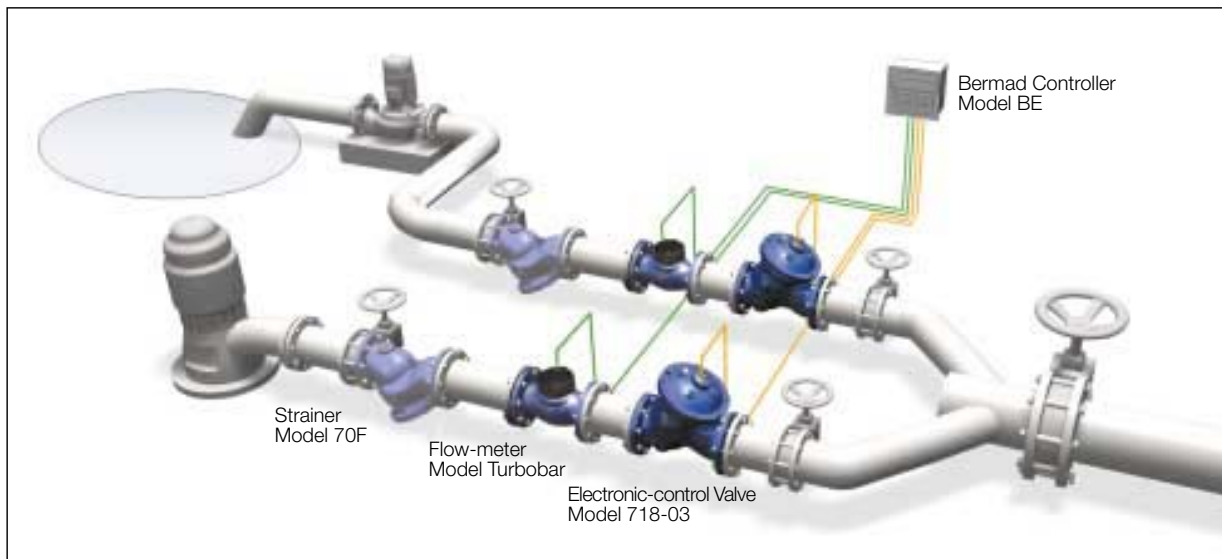

The controller receives continuous inputs from both flow transducers and corrects, in real-time, the opening of each valve, thus maintaining constant flow-ratio between the two sources to achieve the desired result.

- Combination of both **Types A and B** is available also

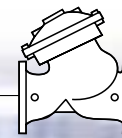

## 700 Series Model 718-03

### Technical Data

#### Dimensions and Weights

Size	A, B		C		L		H		Weight	
mm inch	mm inch	mm inch	mm inch	mm inch	mm inch	mm inch	kg	lbs	kg	lbs
40	1 1/2"	350 14	180 7	205 8.1	239 9.4	9.1	20			
50	2"	350 14	180 7	210 8.3	244 9.6	10.6	23			
65	2 1/2"	350 14	180 7	222 8.7	257 10.1	13	29			
80	3"	370 15	230 9	250 9.8	305 12.0	22	49			
100	4"	395 16	275 11	320 12.6	366 14.4	37	82			
150	6"	430 17	385 15	415 16.3	492 19.4	75	165			
200	8"	475 19	460 18	500 19.7	584 23.0	125	276			
250	10"	520 21	580 23	605 23.8	724 28.5	217	478			
300	12"	645 22	685 27	725 28.5	840 33.1	370	816			
350	14"	645 22	685 27	733 28.9	866 34.1	381	840			
400	16"	645 26	965 38	990 39.0	1108 43.6	846	1865			
450	18"	645 26	965 38	1000 39.4	1127 44.4	945	2083			
500	20"	645 26	965 38	1100 43.3	1167 45.9	962	2121			

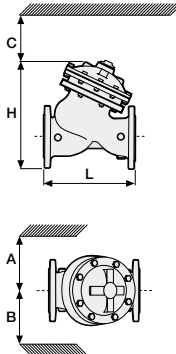

Data is for Y-pattern, flanged, PN16 valves  
Weight is for PN16 basic valves  
"C" enables removing the actuator in one unit  
"L", ISO standard lengths available  
For more dimensions and weights tables, refer to Engineering section

#### Flow Chart

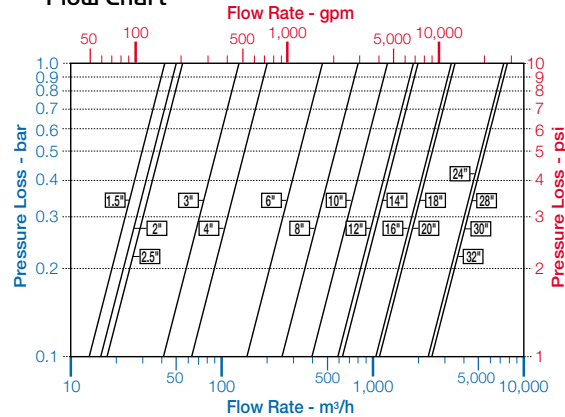

Data is for Y-pattern, flat disc valves  
For more flow charts, refer to Engineering section

#### Main Valve

**Valve Patterns:** "Y" (globe) & angle  
**Size Range:** 1 1/2"-32" (40-800 mm)  
**End Connections (Pressure Ratings):**  
**Flanged:** ISO PN16, PN25 (ANSI Class 150, 300)  
**Threaded:** BSP or NPT  
**Others:** Available on request  
**Working Temperature:**  
Water up to 80°C (180°F)  
**Standard Materials:**  
**Body & Actuator:** Ductile iron  
**Internals:**  
Stainless steel, bronze & coated steel  
**Diaphragm:**  
NBR (Buna N) Nylon fabric-reinforced  
**Seals:** NBR (Buna N)  
**Coating:**  
Fusion Bonded Epoxy, RAL 5005 (Blue)  
NSF & WRAS approved or Electrostatic  
Polyester Powder, RAL 6017 (Green)

#### Control System

**Standard Materials:**  
Bronze, brass, stainless steel &NBR (Buna N)  
**Accessories:**  
Bronze, brass, stainless steel &NBR (Buna N)  
**Tubing:** Copper or stainless steel  
**Fittings:** Forged brass or stainless steel  
**Solenoid Standard Materials:**  
**Body:** brass or stainless steel  
**Elastomers:** NBR or FPM  
**Enclosure:** Molded epoxy  
**Solenoid Electrical Data:**  
**Voltages:**  
(ac): 24, 110-120, 220-240, (50-60 Hz)  
(dc): 12, 24, 110, 220  
**Power Consumption:**  
(ac): 30 VA, inrush; 15 VA (8W), holding or 70 VA, inrush; 40 VA (17.1W), holding  
(dc): 8-11.6W

Values might vary according to specific solenoid model

#### Solenoid Selection

Valve Size	Solenoid Model			
	330	311	281	404
1 1/2"-8" (40-200 mm)	■			
1 1/2"-6" (40-150 mm)		■		
10-20" (250-500 mm)			■	
8-20" (200-500 mm)				■
24 -32" (600-800 mm)			■	
24 -32" (600-800 mm)				■

PN 16    PN 25

The valve control-loop consist of two solenoids

Solenoids Location	Main Valve Position		
	N.O.	N.C.	L.P.
Upstream (inlet)	N.C.	N.O.	N.C.
Downstream (outlet)	N.O.	N.C.	N.C.

### How to Order

Please specify the requested valve in the following sequence: (for more options, refer to Ordering Guide)

Sector	Size	Primary Feature	Additional Feature	Pattern	Body Material	End Connections	Coating	Voltage & Position	Tubing & Fittings	Additional Attributes	
WW	6"	718	03	Y	C	16	EB	4AP	CB	VI	
Waterworks	1 1/2" - 32"	Electronic-Control		Oblique (up to 20") Angle (up to 18") Globe (24-32" only)	Y A G	Polyester Green Polyester Blue Epoxy FB Blue Uncoated	PG PB EB UC	Copper Tubing & Brass Fittings Plastic Tubings & Brass Fittings St. St. 316 Tubing & Fittings	CB PB NN		
No Additional Feature			00		Ductile Iron Standard					Powered opening & closing	B
Closing and Opening Speed-Control			03		Cast Steel					Valve Position Indicator	I
Automatic Regulation Override			09		St. Steel 316					V-Port Throttling Plug	V
Check Valve			20		Nickel Alumin. Bronze					Large Control Filter	F
Solenoid-Controlled & Check Valve			25							Electric Limit-Switch	S
Multi-Setting Levels - Electrically Selected			45		ISO-16	16	24VAC/50Hz - N.C.	4AC		Valve Position Transmitter	Q
Downstream Over-Pressure Guard			48		ISO-25	25	24VAC/50Hz - N.O.	4AO		Flow Over the Seat	O
Hydraulic Remotely-Controlled			50		ANSI-150	A5	24VDC - N.C.	4DC		St. St. 316 Control Accessories	N
Solenoid-Controlled			55		ANSI-300	A3	24VDC - N.O.	4DO		St. St. 316 Internal Trim (Closure & Seat)	T
Electric Override			59		JIS-16	J6	24VDC - L.P.	4DP		St. St. 316 Actuator Internal Assembly	D
					JIS-20	J2	220VAC/50-60Hz N.C.	2AC		Delrin Bearing	R
							220VAC/50-60Hz N.O.	2AO		Viton Elastomers for Seals & Diaphragm	E

Multiple choices permitted

